

|  |    |
|--|----|
| The FCC Wants You to Know .....                              | 2  |
| Installation .....   | 2  |
| Attaching the Microphone Holder .....                        | 2  |
| Mounting the CB .....  | 2  |
| Connecting the Microphone .....                              | 3  |
| Connecting an Antenna .....                                  | 3  |
| Connecting Vehicle Battery Power .....                       | 4  |
| Connecting an External Speaker .....                         | 4  |
| Using the CB As a Base Station .....                         | 4  |
| Operation .....  | 5  |
| Receiving Transmissions and Setting Squelch .....            | 5  |
| Changing Channels Using the Controls on the Microphone ..... | 6  |
| Dual Watch and Memory Setting .....                          | 6  |
| Transmitting .....   | 6  |
| Listening to the Weather Band .....                          | 6  |
| Digital Weather Alert .....                                  | 6  |
| Weather Channel Frequencies .....                            | 7  |
| Using Compass .....  | 7  |
| Calibrating the Electronic Compass .....                     | 8  |
| Transmission Courtesy .....                                  | 8  |
| Maximum Range .....  | 8  |
| Reducing Noise .....   | 8  |
| Using Common 10-Codes .....                                  | 9  |
| Troubleshooting .....  | 10 |
| Care .....   | 10 |
| Replacing the Fuse .....                                     | 10 |
| Specifications .....   | 11 |

---

# Mobile CB with Compass, Dual Watch and Digital Weather Alert

OWNER'S MANUAL — Please read before using this equipment.

Your RadioShack 40-Channel Mobile CB Radio provides two-way communications on the citizen's radio band and lets you tune to local and national weather service broadcasts. You can also connect optional equipment to your CB such as external speakers, or a DC power supply and base antenna to set up a base station in your home. The built-in 40-channel PLL (phase-locked loop) frequency synthesizer uses a precise frequency reference crystal for reliable and exact tuning.

Ideal for recreational, business, or emergency use, your CB has these features:

**Electronic Compass** — provides accurate heading information.

**Dual Watch** — checks one channel while receiving another channel so you do not miss important transmissions. Dual Watch defaults to channel 9 (emergency call channel).

**NOAA (National Oceanic and Atmospheric Administration) 7-Channel WX Band Receiver** — lets you tune to seven national weather service frequencies which provide local weather conditions and forecasts.

**WX Channel Autoscan** — In CB mode, when a weather station carrier is lost, the CB automatically scans weather channels so it can detect a weather alert signal transmitted with a weather signal.

**WX/Signal Indicator** — shows the CB is ready to receive and indicates the reception of a weather alert.

**Digital Weather Alert** — uses Specific Area Message Encoding (SAME) digital information to determine and display the level of

weather events (does not limit alerts to a specific area).

**ACE (Audio Clarity Enhancer)** — suppresses noise levels while leaving the signal intact during reception. It enhances the transmission and provides a significant reduction in transmission and reception noise.

**RF Gain Control** — prevents overloading due to strong RF signals.

**Convenient On-Microphone Channel Up/Down Controls** — let you quickly scan the band for communications.

**Universal Mounting Bracket** — lets you mount your CB securely in your vehicle.

**Specialized Squelch Circuit** — compensates for fading signals and eliminates signal chopping during reception.

**Maximum Allowable Legal Power Output** — gives you the greatest available range.

**TX Indicator** — lights to show when the radio is transmitting.

**Digital Channel Display** — makes the channel number easy to see.

**External Speaker Jack** — lets you connect your CB to an external speaker.

**Screw-On Mic Connector** — ensures a secure microphone connection.

To use this CB, you need a mobile or base station antenna. Your local RadioShack store has a wide variety of antennas. For more information, see "Connecting an Antenna" on Page 3.

## THE FCC WANTS YOU TO KNOW

The Federal Communications Commission (FCC) does not require you to have a license to operate this CB. However, the FCC does require that you read and know Part 95 of *FCC Rules*. These rules apply to the operation of a Class D CB. We have provided a copy of these regulations with your CB.

**Warning:** Do not open your CB to make any internal adjustments. Any internal adjustments can be made only by an authorized service technician.

Unauthorized internal adjustments and/or modifications can lead to illegal operation as defined by Part 95 of *FCC rules*. Such illegal operation can lead to very serious consequences.

Your CB might cause TV or radio interference even when it is operating properly. To determine whether your CB is causing the interference, turn off your CB. If the interference goes away, your CB is causing it. Try to eliminate the interference by either moving your CB away from the receiver or contacting your local RadioShack store for help. If you cannot eliminate the interference, the FCC requires that you stop using your CB.

If you cannot eliminate the interference, contact your local RadioShack store for help.

## INSTALLATION

### Attaching the Microphone Holder

You can connect the microphone holder to either side of the CB or to another location in your vehicle. To attach the holder to either side of the CB, horizontally or vertically, se-

sure it using the supplied small screws and lock washers.

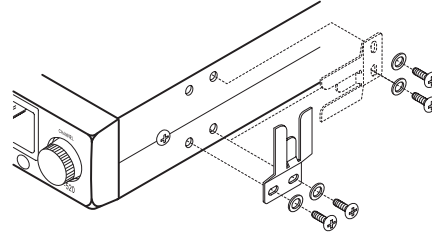

To attach the holder to another location in the vehicle, such as the dashboard, follow these steps.

1. Using the holder as a template, mark the positions for the mounting screw holes at the desired location.
2. At each marked position, drill a small starter hole for the supplied mounting screws.

**Caution:** Be careful not to drill into anything behind the mounting surface.

3. Attach the holder at the mounting location using the supplied small screws and lock washers.

### Mounting the CB

The most common mounting location for this CB is under a vehicle's dashboard. However, if you use the CB as a base station, you can place it on a desk, shelf, or table (see "Using the CB As a Base Station" on Page 4).

If you are mounting the CB in a vehicle, choose a location where:

- you can easily reach the CB.
- wires and cables are clear of the vehicle's pedals or other moving parts.
- the CB is not directly in front of heating vents.

- the magnetic fields caused by the vehicle's wiring do not affect the CB. (See "Calibrating the Electronic Compass" on Page 8.)
- all wires and cables can reach their connection points.

**Warning:** If you use the CB in a vehicle, mount it securely to avoid damage to the CB or vehicle or injury to anyone in the vehicle during sudden starts or stops.

Follow these steps to mount the CB using the supplied hardware.

1. Using the mounting bracket as a template, mark the positions for the screw holes on the mounting surface.
2. In each marked position, drill a small starter hole for the supplied mounting screws.

**Caution:** Be careful not to drill into objects behind the mounting surface.

3. Attach the mounting bracket to the mounting surface with the supplied screws and lock washers.

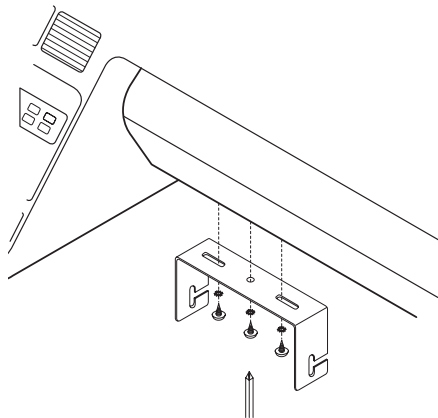

4. Attach the CB to the mounting bracket using the supplied rubber washers and mounting knobs.

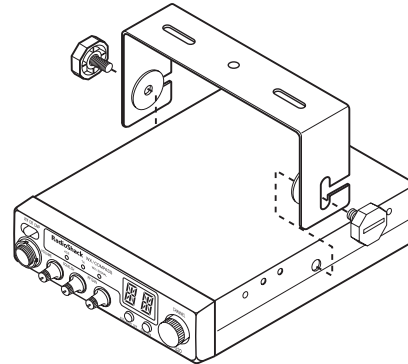

**Note:** To use the radio's compass mode correctly, you have to install the CB horizontally.

### Connecting the Microphone

1. Align the slot on the top of the microphone's plug with the ridge inside the microphone jack. Then fully insert the plug into the jack.
2. Turn the plug's locking nut clockwise to tighten it.
3. Slide the microphone onto the microphone holder.

To disconnect the microphone from the CB, unscrew the locking nut then pull out the plug.

**Caution:** Never pull on the microphone's cable.

### Connecting an Antenna

There are many different types of CB antenna for mobile CBs. Each antenna type has its own benefits, so choose the one that best meets your needs. Your local RadioShack store sells a wide variety of antennas.

For the best performance you should mount the antenna:

- as high as possible on the vehicle

- as far as possible from an electrical noise source
- vertically

**Note:** If you are using this CB as a base station, see “Using the CB As a Base Station” .

Once you choose an antenna, follow its mounting instructions. Then route the cable (not supplied) to the CB and connect the cable to the **ANTENNA** jack on the back of the CB.

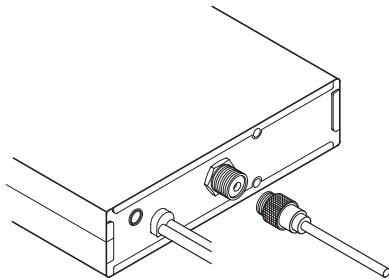

**Cautions:**

- Avoid routing the cable next to sharp edges or moving parts, which might damage the cable.
- Do not run the cable next to power cables or other radio antenna cables.
- Do not run the cable through the engine compartment or other areas that produce extreme heat.

For maximum range, adjust the antenna's Standing Wave Ratio (SWR) using an SWR meter (not supplied).

Follow the instructions supplied with the SWR meter and antenna to adjust your antenna's SWR to the lowest possible value. SWR values of 2.0:1 are generally acceptable, with readings of 1.5:1 or lower being more desirable.

**Connecting Vehicle Battery Power**

Follow these steps to connect the CB to vehicle battery power.

1. Connect the red wire (with the in-line fuse holder) on the back of the CB to a terminal in your vehicle's fuse box that has power only when the ignition is in the ACC (accessory) or ON position.
2. Connect the black ground wire to a metal part of the vehicle's frame (chassis ground).

**Caution:** Do not connect the black wire to a non metallic (plastic) part, or to any part insulated from the vehicle's chassis by a non-metallic part.

**Connecting an External Speaker**

You can connect an optional external speaker to the CB. Only use an 8-ohm speaker with a 1/8-inch (3.5-mm) plug. Insert the speaker's plug into the CB's **EXT** jack. Your local RadioShack store carries a wide selection of suitable speakers.

**USING THE CB AS A BASE STATION**

Although this CB is designed mainly for mobile use, you can also use it as a base station with an AC power source. For base station installation, you need these items (not supplied).

- a 13.8-volt DC power supply that supplies at least 1.6 amps

**Caution:** Most 13.8-volt DC power supplies plug into a standard AC outlet to produce DC power. Before connecting your CB to a 13.8-volt DC power supply, read and follow the instructions included with the power supply.

- base station antenna
- coaxial antenna cable and connectors

**Note:** Your local RadioShack store carries a wide selection of base station antennas, coaxial antenna cables, and connectors. In addition,

tion, you can choose from a selection of suitable base station power supplies.

Follow these steps to install the CB as a base station.

1. Mount the base station antenna as described in its owner's manual.

**Warning:** Use extreme caution when you install or remove a base station CB antenna. If the antenna starts to fall, let it go. It could contact overhead power lines. If the antenna touches a power line, contact with the antenna, mast, cable, or guy wires can cause electrocution and death. Call the power company to remove the antenna. DO NOT attempt to do so yourself.

2. Connect the antenna to the **ANTENNA** jack on the back of the CB.
3. Connect the CB's black power wire to the negative (-) terminal on the DC power supply.

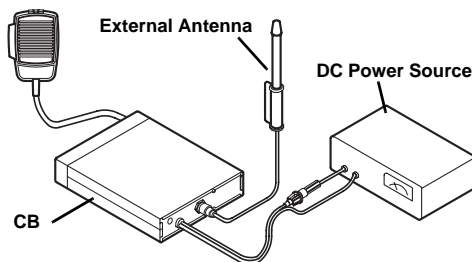

4. Connect the CB's red wire (with the in-line fuse) to the positive (+) terminal on the DC power supply.
5. Connect the DC power supply to a standard AC outlet.

## OPERATION

Before you use your CB, you should know how to use it effectively and courteously. "Transmission Courtesy" on Page 8 contains

information that will help you get more enjoyment from your CB.

**Caution:** Do not attempt to use your CB without first connecting it to an antenna.

## Receiving Transmissions and Setting Squelch

1. Set **WX/CB/CMP** to **CB**.
2. Turn **SQUELCH** fully counterclockwise.
3. Turn **RF GAIN** fully clockwise.
4. Turn on the CB by turning **OFF/VOLUME** clockwise. The display lights and the channel appears.

**Note:** The CB sounds an alert if it detects a weather alert signal (see "Digital Weather Alert" on Page 6).

5. Rotate **VOLUME** clockwise until you hear a hissing sound.
6. Slowly turn **SQUELCH** clockwise until the hissing sound stops.

**Note:** To receive very weak signals, turn **SQUELCH** counterclockwise. You hear noise between transmissions, but you can also hear weak transmissions (those not strong enough to break through a higher squelch setting). If the CB picks up unwanted, weak transmissions, turn **SQUELCH** clockwise to reduce the CB's sensitivity to these signals.

7. Turn **RF GAIN** counterclockwise to decrease the incoming signal strength and prevent overloading. Or, turn it clockwise to receive the maximum possible signal.
8. Rotate **CHANNEL** to select a channel.
9. Adjust **VOLUME** to a comfortable listening level.

**Note:** To improve communication quality, press **ACE/ALERT OFF**. The ACE indicator lights. See “Reducing Noise” on Page 8.

**Notes:**

- The ACE circuit does not operate when you select **WX**.
- You cannot turn on the ACE circuit while holding down the talk button.

To turn off the CB, turn **OFF/VOLUME** counterclockwise until it clicks.

### Changing Channels Using the Controls on the Microphone

To tune to the next higher or lower channel, press **UP** or **DOWN** on the microphone.

To quickly change channels in either direction, hold down **UP** or **DOWN** until you reach the desired channel.

To prevent accidentally changing the channel with **UP** or **DOWN**, press **LOCK**. Press **LOCK** again to restore the **UP** or **DOWN** operation.

### Dual Watch and Memory Setting

You can set the CB to check a sub channel (Channel 9 is preset) while receiving the main channel. If the CB finds a signal on the sub channel, it automatically switches to it.

To use dual watch, select the main channel, then press **DUAL/MEM**. Press **DUAL/MEM** again to turn off dual watch.

To change the sub channel from Channel 9 to another channel:

1. Select the desired channel for sub channel.
2. Press and hold **DUAL/MEM** for about 2 seconds.
3. Select the main channel and press **DUAL/MEM**.

**Note:** Using the microphone to either transmit or change channels up and down will turn off dual watch.

### Transmitting

**Note:** We recommend you try receiving transmissions before you transmit.

1. To transmit, press the talk button on the side of the microphone. Hold the microphone about 2 or 3 inches from your mouth and speak in a normal tone. The TX indicator lights.
2. When you finish transmitting, release the talk button. The TX indicator turns off.
3. To turn off the CB, turn **OFF/VOLUME** counterclockwise until it clicks.

### Listening to the Weather Band

The National Oceanic and Atmospheric Administration (NOAA) broadcasts local forecast and regional weather information on one or more of seven channels in the US. All seven frequencies are preprogrammed in this CB. (See “Weather Channel Frequencies” on Page 7.)

To select a weather broadcast, set **WX/CB/CMP** to **WX**, and turn **CHANNEL** to select one of the frequencies. Set **WX/CB/CMP** to **CB** to return to normal CB operation. The CB also detects severe weather alert signals in CB mode.

**Note:** The microphone’s talk button does not work when **WX/CB/CMP** is set to **WX**.

### Digital Weather Alert

When your local weather station broadcasts a severe weather alert signal, the radio sounds an alert tone and the radio’s SAME alert indicator lights according to the emergency level encoded in the signal.

To turn the weather alert off, press **ACE/ALERT OFF**.

| Alert Type | Display   | Sound      |
|------------|-----------|------------|
| Warning    | <b>W</b>  | Siren      |
| Watch      | <b>WT</b> | Siren      |
| Statement  | <b>ST</b> | Rapid Beep |
| Test       | <b>TE</b> | Rapid Beep |

**Notes:**

- Because of atmospheric conditions, you might encounter times when the signal your radio receives does not contain information relevant to the emergency level of the alert. This is normal.
- The CB sounds an alert regardless of the channel setting.
- The CB does not sound an alert while you are transmitting.
- The weather alert indications remain on the display until you press **ACE/ALERT OFF**.
- If the carrier of the current weather channel is lost, the WX/SIGNAL indicator flashes. (In CB mode, the CB automatically scans weather channels so it can detect a weather alert signal. While the CB scans weather channels, the WX/SIGNAL indicator flashes until the CB receives a weather station signal.)
- In the CB mode, the display automatically changes from the CB channel number to the weather alert indication when the CB receives a SAME alert signal. You can hear your local forecast and regional weather information immediately. Press **ACE/ALERT OFF** or the PTT (Press To Talk) button on the microphone to return to the CB channel number.

**Caution:** If you are in a rural or fringe area, your radio might be triggered by an alert

broadcast for one area, but not for another area.

To verify actual reception, your radio must receive a test or emergency alert broadcast. In the US, the National Weather Service (NWS) broadcasts a test alert every week on Wednesday between 11 am and 1 pm. For the specific test schedule in your area, contact your local NOAA or NWS office, usually listed in the telephone directory under “US Government, Department of Commerce.”

**Weather Channel Frequencies**

Your CB is preprogrammed with the following US weather service channel FM frequencies:

| Channel | Frequency (MHz) |
|---------|-----------------|
| WX 1    | 162.400         |
| WX 2    | 162.425         |
| WX 3    | 162.450         |
| WX 4    | 162.475         |
| WX 5    | 162.500         |
| WX 6    | 162.525         |
| WX 7    | 162.550         |

**Using Compass**

Your CB’s electronic compass displays eight different headings:

**N, E, S, W, NE, NW, SE, SW**

The compass does not disrupt receive or transmit functions.



## Calibrating the Electronic Compass

You must calibrate the electronic compass in your area before using it. The calibration allows the electronic compass to separate the earth's magnetic field from the magnetic fields generated by external influences such as your vehicle so that the electronic compass provides accurate heading information.

Before beginning the calibration, you must install the CB in your vehicle. The calibration is best performed on a leveled section of pavement, such as an empty parking lot.

### Notes:

- Depending on your vehicle's wiring and the placement of the CB in relation to the magnetic fields created by that wiring, there could be a slight delay in the CB compass' ability to calculate the correct direction. For minimal delays in directional calculations, try different placements of the CB installation. (See "Mounting the CB" on Page 2.)
- You may need to recalibrate the compass if you change the CB's placement.

1. Set **WX/CB/CMP** to **CMP**.
2. Press and hold **DUAL/MEM** and press **ACE/ALERT OFF**. **CR** appears.
3. Press **DUAL/MEM**. **CR** flashes.
4. Drive your car in a circle for two full turns.
5. Press **DUAL/MEM**.

## Transmission Courtesy

Follow these guidelines when using your CB.

- Wait for a pause in someone else's transmission before you ask for a break.

- If you do not receive an answer to your call after a second attempt, sign off and wait several minutes before trying again.
- Do not hold down the talk button when you are not talking. (This is called dead keying).
- Assist callers with directions, information about road conditions, and any other reasonable requests.

## Maximum Range

The maximum range and quality of CB transmissions vary depending on the following conditions.

- the type and quality of antenna used
- the height of the antenna's mounting location — the higher the antenna, the better the signal's range
- the surrounding terrain mountains and tall buildings limit the range
- weather conditions
- the number of nearby CBs operating on the same channel
- standing wave ratio (SWR) between the antenna and the CB.

**Note:** Your CB radio's transmission range is generally line-of-sight.

## Reducing Noise

The Audio Clarity Enhance (ACE) circuit uses compander (compressor and expander) technology to improve communication quality. The circuit maintains the dynamic range while increasing the signal-to-noise ratio as the gain is automatically controlled according to the input signal level. This results in a reduction in wide band noise.

Because your CB is exceptionally quiet, any noise you hear is probably from an external

source in you vehicle, such as the alternator, another radio, or spark plugs.

To determine the noise's source, turn off the engine and operate the CB with your ignition set to ACC. If the noise is reduced, the problem is your vehicle's ignition or electrical system.

Here are a few hints to reduce such noise:

- Make all CB power and antenna wires as short as possible.
- Keep the power wires away from the antenna wires.

- Be sure the chassis ground connection is secure.
- Replace old ignition wires with new, high-voltage, noise-suppression wires.
- Install noise suppressors on your spark plugs, or install new spark plugs that have built-in noise suppressors.
- If problems persist, check your alternator/generator and regulator gauges. You can reduce the noise from these sources by using bypass capacitors at the various output voltage points.

Your local RadioShack store has a wide selection of noise-suppression accessories.

## Using Common 10-Codes

CB users have adopted the 10-codes for standard questions and answers.

This table lists common codes adopted by the Associated Public Safety Communications Officers (APCO).

| CODE  | MEANING                             | CODE  | MEANING                       |
|-------|-------------------------------------|-------|-------------------------------|
| 10-1  | Receiving poorly                    | 10-22 | Report in person to           |
| 10-2  | Receiving well                      | 10-23 | Please stand by               |
| 10-3  | Stop transmitting                   | 10-25 | Can you contact               |
| 10-4  | OK, message received                | 10-26 | Disregard last information    |
| 10-5  | Relay message                       | 10-27 | I am moving to channel        |
| 10-6  | Busy, please stand by               | 10-28 | Identify your station         |
| 10-7  | Out of service                      | 10-32 | I will give you a radio check |
| 10-8  | In service                          | 10-33 | Emergency traffic             |
| 10-9  | Repeat message                      | 10-36 | Correct time is               |
| 10-10 | Transmission completed, standing by | 10-37 | Wrecker needed at             |
| 10-11 | Talking too rapidly                 | 10-38 | Ambulance needed at           |
| 10-12 | Visitors present                    | 10-41 | Please turn to channel        |
| 10-13 | Advise Weather/road conditions      | 10-42 | Traffic accident at           |
| 10-17 | Urgent business                     | 10-43 | Traffic tie-up at             |
| 10-18 | Anything for us                     | 10-50 | Break channel                 |
| 10-19 | Nothing for you. Return to base     | 10-62 | Unable to copy; use telephone |
| 10-20 | My location is                      | 10-70 | Fire at                       |
| 10-21 | Call by telephone                   |       |                               |

## TROUBLESHOOTING

We do not expect you to have any problem with your CB, but if you do, the following suggestions might help.

| Symptom                         | Suggestion  |
|---------------------------------|---|
| Trouble receiving               | Make sure power is on. Turn <b>VOLUME</b> clockwise.                        |
|                                 | Make sure <b>SQUELCH</b> is adjusted properly.                              |
|                                 | Be sure <b>RF GAIN</b> is fully clockwise.                                  |
|                                 | Make sure the CB is set to an operating channel.                            |
|                                 | Make sure the microphone is securely connected.                             |
|                                 | Press <b>ACE/ALERT OFF</b> to improve communication quality.                |
|                                 | Check for a good antenna connection.  |
|                                 | Make sure the antenna cable is securely connected to the antenna connector. |
|                                 | Make sure the antenna is fully extended.                                    |
|                                 | Make sure all connections are secure and free of corrosion.                 |
|                                 | Make sure <b>CB/WX/CMP</b> is set to <b>CB</b> or <b>CMP</b> .              |
| The CB is completely inoperable | Check the DC power cord and in-line fuse.                                   |
|                                 | Replace the fuse. See "Replacing the Fuse" on Page 10.                      |

If these tips do not solve the problem, do not attempt repairs or adjustments yourself. The CB should be serviced only by a qualified radio technician. If you still have problems, take your CB to your local RadioShack store for assistance.

### Care

Keep the CB dry; if it gets wet, wipe it dry immediately. Use and store the CB only in normal temperature environments. Handle the CB carefully; do not drop it. Keep the CB away from dust and dirt, and wipe it with a damp cloth occasionally to keep it looking new.

Modifying or tampering with the CB's internal components can cause a malfunction and might invalidate its warranty and void your FCC authorization to operate it. If your CB is not performing as it should, take it to your local RadioShack store for assistance.

### Replacing the Fuse

The CB's 2-amp in-line fuse helps protect your CB from power surges and short circuits.

When replacement is required, use a 2-amp, fast-acting glass fuse, available at your local RadioShack store.

Follow these steps to replace the fuse.

1. Make sure the vehicle and CB are both off.

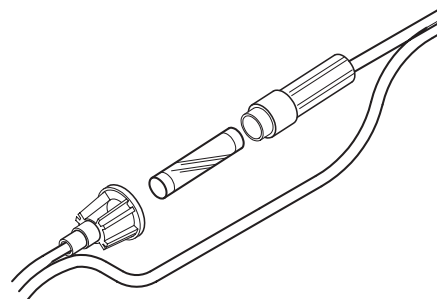

2. Hold the fuse holder at both ends, push the ends together, twist one end counter-clockwise, and pull them apart.
3. Remove the old fuse and inspect its condition. If it is blown, insert a new one of the same type and rating. If it is not blown, reinsert it.

**Caution:** Do not use a fuse with ratings other than those specified here. Doing so might damage your CB.

4. Push the fuse holder ends together and twist one end clockwise.

## SPECIFICATIONS

### General

|                         |   |
|-------------------------|---|
| Channels .....          | 40 Channels                                   |
| Frequency Range .....   | 26.965 MHz to 27.405 MHz                      |
| Power Requirement ..... | 13.8V DC (12–16 Volts DC, Negative Ground)    |
| Dimensions (HWD) .....  | 1.36 × 5.51 × 7.09 Inches (35 × 140 × 180 mm) |
| Weight .....            | 29.98 ounces (0.850 kg)                       |

### Receiver

|                                  |                                   |
|----------------------------------|-----------------------------------|
| Sensitivity .....                | 0.5µV or better for 10 dB (S+N)/N |
| Adjacent Channel Rejection ..... | 50 dB (at 10 kHz)                 |
| Audio Output .....               | 4.5 Watts (Maximum)               |
| Frequency Response .....         | 450–2500 Hz                       |

### Intermediate Frequency

|                        |                                |
|------------------------|--------------------------------|
| 1st IF .....           | 10.695 MHz                     |
| 2nd IF .....           | 455 kHz                        |
| Cross Modulation ..... | 50 dB                          |
| Squelch .....          | Adjustable from 0.5 µV to 1 mV |

### Transmitter

|  |   |
|--|---|
| Output Power .....                     | 4 Watts (FCC Maximum)                                   |
| Type of Modulation .....               | AM Double-Sideband, Full Carrier Modulation             |
| Modulation Capability .....            | ± 90%   |
| Spurious Emission .....                | Less than – 70 dB                                       |
| Frequency Tolerance .....              | ± 200 Hz  |
| Antenna Impedance .....                | 50 Ohm  |
| Current Drain (13.8-volt supply) ..... | 1 Amp with No Modulation (1.6 Amps with 80% Modulation) |

Specifications are typical; individual units might vary. Specifications are subject to change and improvement without notice.

### Limited Ninety-Day Warranty

This product is warranted by RadioShack against manufacturing defects in material and workmanship under normal use for ninety (90) days from the date of purchase from RadioShack company-owned stores and authorized RadioShack franchisees and dealers. EXCEPT AS PROVIDED HEREIN, RadioShack MAKES NO EXPRESS WARRANTIES AND ANY IMPLIED WARRANTIES, INCLUDING THOSE OF MERCHANTABILITY AND FITNESS FOR A PARTICULAR PURPOSE, ARE LIMITED IN DURATION TO THE DURATION OF THE WRITTEN LIMITED WARRANTIES CONTAINED HEREIN. EXCEPT AS PROVIDED HEREIN, RadioShack SHALL HAVE NO LIABILITY OR RESPONSIBILITY TO CUSTOMER OR ANY OTHER PERSON OR ENTITY WITH RESPECT TO ANY LIABILITY, LOSS OR DAMAGE CAUSED DIRECTLY OR INDIRECTLY BY USE OR PERFORMANCE OF THE PRODUCT OR ARISING OUT OF ANY BREACH OF THIS WARRANTY, INCLUDING, BUT NOT LIMITED TO, ANY DAMAGES RESULTING FROM INCONVENIENCE, LOSS OF TIME, DATA, PROPERTY, REVENUE, OR PROFIT OR ANY INDIRECT, SPECIAL, INCIDENTAL, OR CONSEQUENTIAL DAMAGES, EVEN IF RadioShack HAS BEEN ADVISED OF THE POSSIBILITY OF SUCH DAMAGES.

Some states do not allow limitations on how long an implied warranty lasts or the exclusion or limitation of incidental or consequential damages, so the above limitations or exclusions may not apply to you.

In the event of a product defect during the warranty period, take the product and the RadioShack sales receipt as proof of purchase date to any RadioShack store. RadioShack will, at its option, unless otherwise provided by law: (a) correct the defect by product repair without charge for parts and labor; (b) replace the product with one of the same or similar design; or (c) refund the purchase price. All replaced parts and products, and products on which a refund is made, become the property of RadioShack. New or reconditioned parts and products may be used in the performance of warranty service. Repaired or replaced parts and products are warranted for the remainder of the original warranty period. You will be charged for repair or replacement of the product made after the expiration of the warranty period.

This warranty does not cover: (a) damage or failure caused by or attributable to acts of God, abuse, accident, misuse, improper or abnormal usage, failure to follow instructions, improper installation or maintenance, alteration, lightning or other incidence of excess voltage or current; (b) any repairs other than those provided by a RadioShack Authorized Service Facility; (c) consumables such as fuses or batteries; (d) cosmetic damage; (e) transportation, shipping or insurance costs; or (f) costs of product removal, installation, set-up service adjustment or reinstallation.

This warranty gives you specific legal rights, and you may also have other rights which vary from state to state.

RadioShack Customer Relations, 200 Taylor Street, 6th Floor, Fort Worth, TX 76102

*We Service What We Sell*

12/99