

**This Manual is provided by**  
**CBTricks.com**

Someone who wanted to help you repair your equipment  
scanned this manual.

If you would like to help us put more manuals online support us.

Supporters of CBTricks.com paid for the hosting so you would have this file.

CBTricks.com is a non-commercial personal website was created to help promote the exchange of service, modification, technically oriented information, and historical information aimed at the Citizens Band, GMRS (CB "A" Band), MURS, Amateur Radios and RF Amps.

CBTricks.com is not sponsored by or connected to any Retailer, Radio, Antenna Manufacturer or Amp Manufacturer, or affiliated with any site links shown in the links database. The use of product or company names on my web site is not endorsement of that product or company.

If your company would like to provide technical information to be featured on this site I will put up on the site as long as I can do it in a non-commercial way.

The site is supported with donation from users, friends and selling of the Galaxy Service Manual CD to cover some of the costs of having this website on the Internet instead of relying on banner ads, pop-up ads, commercial links, etc. to pay my costs. Thus I do not accept advertising banners or pop-up/pop-under advertising or other marketing/sales links or gimmicks on my website.

ALL the money from donations is used for CBTricks.com I didn't do all the work to make money (I have a day job). This work was not done for someone else to make money also, for example the ebay CD sellers.

All Trademarks, Logos, and Brand Names are the property of their respective owners.  
This information is not provided by, or affiliated in any way with any radio or antenna Manufacturers.  
Thank you for any support you can give.

## SPECIFICATIONS

### RECEIVER

CIRCUIT TYPE ..... Dual conversion superheterodyne; crystal-controlled 23 channel reception with "fine tuning" capability of 2.5 Kc on each channel. A crystal frequency synthesizer circuit is used to provide 23 channel operation on transmit and receive.

SENSITIVITY..... 0.8  $\mu$ v for 10 db S  $\neq$  N to N ratio

SELECTIVITY..... 6 Kc bandwidth -26 db

INTERMEDIATE FREQUENCY..... 1st IF 11.275 Mc, 2nd IF 455 Kc.

IMAGE REJECTION ..... -75 db

AUDIO OUTPUT..... 4 watts into 5 x 3" oval speaker.

EXTERNAL SPEAKER IMPEDANCE ..... 4-8 ohms.

AUXILIARY CIRCUITS..... Full-time Automatic Noise Limiter, Adjustable Squelch, AVC.

### TRANSMITTER

PLATE POWER INPUT TO FINAL .. 5 watts

MODULATION ..... AM, via plate modulation; up to 100% capability.

RANGE-BOOST..... Yields high average modulation at all times at average speaking levels.

HARMONIC SUPPRESSION ..... Exceeds FCC requirements.

CARRIER DEVIATION ..... Exceeds FCC requirement of  $\pm$ .005%.

ANTENNA MATCHING..... Will match resistive antenna loads of 50-75 ohms.

TRANS/REC SWITCHING ..... Relay switching, push-to-talk on microphone.

PUBLIC ADDRESS ..... PA facilities using microphone and audio stage in conjunction with an external speaker.

## TUBES & SEMI-CONDUCTORS

		<u>Receiver Function</u>	<u>Transmitter Function</u>
V1	6AN8	RF Amp/1st Mixer	-----
V2	6AN8	2nd Mixer/2nd Osc.	-----
V3	6BA6	IF Amp (455 Kc)	-----
V4	6BA6	IF Amp (455 Kc)	-----
V5	12AX7	1st Audio	Modulator/Mic Preamp
V6	6AQ5	Audio Output	Modulator
V7	6GH8	Local Oscillator,	
V8	6GH8	-----	Converter/1st Osc.
V9	6BA6	-----	Buffer Amp
V10	6BQ5	-----	RF Power Amp
V11	12AT7	-----	Buffer / Synthesizer
D1	1N60	Det, AVC	-----
D2	1S72	ANL	-----
D5	5GF	-----	Range-Boost
D3, D9	SD46	Meter Rectifier ("S")	Meter Rectifier (RF power)
D6, D8	5GJ	B+ Rectifiers (voltage doubler)	
D7	5GJ	Rectifier (Bias Supply)	
D10, D11	5GF	Absorber	

## COMMON

POWER SUPPLY.....	105-120 volts, 50/60 cycles AC or 12 volts DC.
POWER CONSUMPTION .....	117 volts AC: 80 watts max. 12.6 volts DC: 3-1/2 amps (rec), 4 amps (trans).
DIMENSIONS.....	12" W x 5" H x 8-1/4" D (excluding knobs and plugs at rear).
NET WEIGHT.....	17 lbs.
SHIPPING WEIGHT.....	20 lbs.

## GENERAL INSTRUCTIONS

The Lafayette "Comstat 25A" is a combination transmitter and receiver designed for use in Class "D" operation in the 11 meter citizens radio service. It is designed to meet the Federal Communications Commission requirements applicable to equipment operating in this service under class "D" emission, and not to be used for any other purpose. Rules Part 95 of the FCC regulations defines operation in this service and the licensee is required to read and understand these regulations prior to operating a CB transmitter. Copies of Manual VI (covering the FCC regulations for the Citizens Band Radio Service) includes Part 95 and are available for \$1.25 from the Superintendent of Documents, U. S. Government Printing Office, Washington, D. C. A station license may be obtained by submitting a properly completed Station License Application, Form 505 as directed.

It is illegal to operate the transmitter section of this transceiver prior to receiving a valid station license and call sign. NOTE: It is the transmitter that is licensed NOT the operator. Anyone may operate a properly licensed CB transmitter but the licensee will be held responsible for any violations incurred during use. A properly completed Identification Card Form 452-C must be attached to the transmitter.

The transceiver will provide economical and reliable radio communication in its intended application if installed and operated in accordance with instructions contained herein.

## GENERAL DESCRIPTION

### RECEIVER SECTION

The receiver is designed to receive amplitude modulated signals in the 26.965 to 27.255 Mc (11-meter) citizens band. The circuit is a highly sensitive and selective dual-conversion superheterodyne type, with one RF and two IF amplifiers. The unit employs a frequency-synthesized circuit in which 13 crystals (all supplied) are used to provide full 23 channel crystal-controlled operation (receive and transmit), switch-selected from the front panel. The unit is equipped with an 11-pin socket at the rear of the chassis which offers direct plug-in facilities for the Lafayette Priva-Com Selective Call unit.

Features incorporated into the receiver section include an S-meter for reading signal strength, a full time automatic noise limiter, and an adjustable squelch control which can be used to "quiet" the receiver when no signal is being received. As a further aid to better reception, the circuit includes a control that offers "fine tuning" on receive. This control, which has a range of 2.5 Kc, permits optimum reception of stations that are slightly off frequency.

### TRANSMITTER SECTION

The transmitter is designed to transmit amplitude modulated signals in the 26.965 to 27.255 Mc (11-meter) citizens band. The frequency synthesized circuit used for receive is also common to the transmitter and used in the transmit mode to provide full 23 channel crystal-controlled operation. A push-to-talk button on the ceramic microphone (supplied) offers reliable relay switching. Plate modulation is employed (100% capability), with up to 5 watts plate power input to the final RF. Also included is a special "Range-Boost" circuit which, when "on", concentrates more audio power into the sidebands by providing maximum modulation on all syllables. This feature offers maximum communication distance when noisy conditions make reception of your signal difficult. A relative RF power meter (which automatically functions as an S-meter on receive) indicates relative RF power at the antenna. An added feature is a provision for public address, utilizing the microphone and audio circuits to feed an external speaker connected to the Phones output jack.

### POWER SUPPLY

The transceiver is designed to operate from either 105-120 volts, 50/60 cycles AC or 12.6 volts DC. Two power supply cables are supplied -- one for AC operation, the other for DC operation. All that is required is that the appropriate power cable be plugged into the 8-pin power socket on the transceiver. On 12.6 volts DC operation, the transceiver employs a built-in solid-state power supply! circuit (no vibrator is used).

### BASE STATION INSTALLATION

The transceiver should be placed in a convenient operating location, close to an AC power outlet, suitable ground and the antenna lead-in cable.

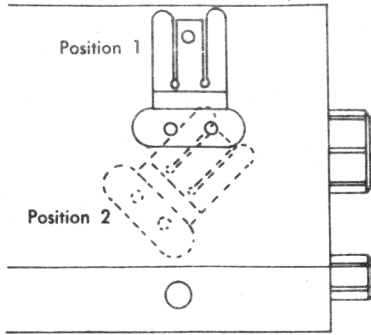

**Figure 1** Microphone bracket installation. Bracket may be attached to either side of the transceiver. If desired, the bracket may be attached in any other convenient location (car dashboard, etc.).

### MICROPHONE BRACKET INSTALLATION

The microphone bracket may be installed on the left or right-hand side of the transceiver in either of the two positions shown in Figure 1, whichever is most convenient.

### MOUNTING BRACKET

The mobile mounting bracket may be used in a base installation by attaching it to the underside of the transceiver as shown in Figure 2, diagram B. When so used, the four rubber feet (supplied) may be attached to the bracket as shown in Figure 2, diagram C. Note that the bracket has additional holes for the front pair of securing screws. These will allow the transceiver to be set to an angle which provides the operation with the best view of the front panel.

### AC POWER CONNECTION

Select the AC power cord and attach the 8-pin female connector to the 8-pin male power connector at the rear of the transceiver. **CAUTION:** Always line up the keyway properly before pushing the cable connector onto the transceiver. Do not attempt to force the connector onto the pins -- when properly lined up, the connector will slip on easily. Making sure the transceiver is off (switch is located at the extreme counter-clockwise of the VOLUME control), insert the AC plug at the other end of the cord into an outlet supplying 105-120 volts, 50/60 cycles AC. For protection, the AC input to the transceiver is fused (the fuse is located within the transceiver).

### MICROPHONE CONNECTION

Attach the 4-pin male connector at the end of coil cord to the 4-pin female connector at the lower left front of the transceiver. Secure it firmly by means of the knurled securing ring.

### ANTENNA CONNECTION

The antenna lead-in cable (RG-58/U or RG-8/U) should be terminated with a PL-259 type male coaxial connector which should then be attached to the matching antenna connector at the rear of the transceiver.

## MOBILE INSTALLATION

### MICROPHONE BRACKET INSTALLATION

The microphone bracket may be installed on the left or right side of the transceiver in one of the two positions shown in Figure 1. The position that must be used will depend on the position of the mobile mounting bracket.

If the mounting bracket is attached to the top of the transceiver (as would be normal in a car installation), it will be necessary to use position 2.

## TRANSCEIVER INSTALLATION

Before installing the transceiver in a car, truck, boat, etc., be sure to choose a location which is convenient to the operating controls, and will not interfere with the normal functions of the driver. The transceiver may be mounted to the underside of the instrument panel or dashboard of a car, truck, etc., by means of the special bracket that is supplied with the transceiver. Remove the bracket from the transceiver by loosening the four large knurled screws at the sides. Attach the bracket to the underside of the instrument panel using the four self-threading screws provided. Figure 2 illustrates the manner in which the transceiver is mounted. Secure the transceiver to the bracket by means of the large knurled screws (two each side). Note that the bracket has additional holes for the front pair of securing screws. These will allow the transceiver to be set to an angle which provides the operator with the best view of the front panel.

## DC POWER CONNECTION

**CAUTION:** This transceiver is designed for use only in vehicles employing a negative ground system. **DO NOT USE IN POSITIVE GROUND VEHICLES.**

The Red lead in the DC power cable (this is the lead that is fused for 8 amps) should be connected to the main positive battery source in the vehicle. "Hot" points normally available are the accessory post on the ignition switch or the accessory side of the fuse block. The Black lead should be connected to the metal firewall or any other point that is connected to the vehicle chassis (negative battery potential). Make sure the Red lead has been connected to a point which provides power only when the ignition switch is turned on.

As a final step, the 8-pin female connector at the other end of the DC power cable should be attached to the 8-pin male power connector at the rear of the transceiver. **CAUTION:** Always line up the keyway properly before pushing the cable connector onto the transceiver. Do not attempt to force the connector onto the pins -- when properly lined up, the connector will slip on easily.

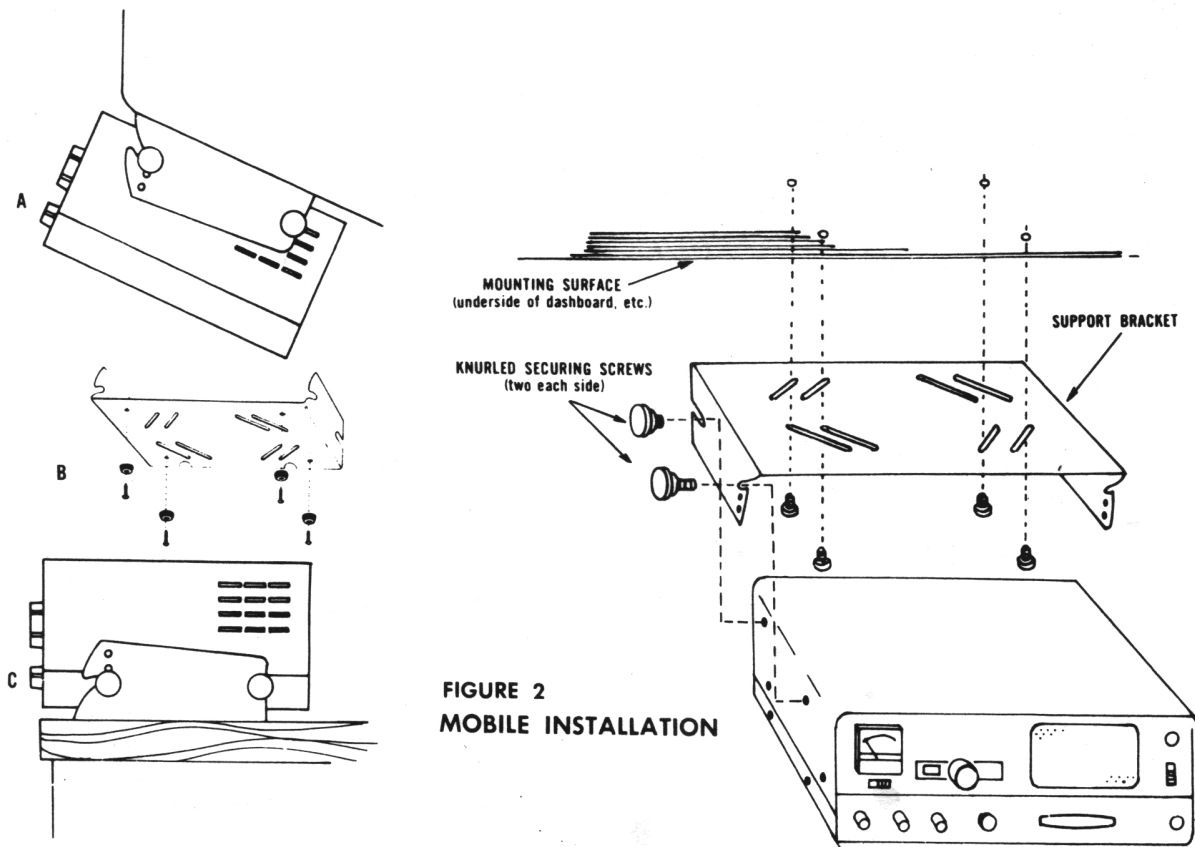

## ANTENNAS

The results obtained with your new Lafayette Citizens Band Transceiver will be greatly determined by the efficiency of the antenna system used.

Due to the complexity of the subject, it is not within the scope of this manual to provide detailed information on antenna systems. Although this section does contain some general information which may be of value to the beginning CB enthusiast, we suggest you purchase one of the numerous books available which covers this subject in greater detail. The Howard W. Sams publication by David E. Hicks, "CB Radio Antenna Guidebook", is particularly recommended. This book offers a complete guide to the selection and installation of CB antennas and includes a great deal of information that will be useful in obtaining optimum results with your antenna system.

### ANTENNA CABLE

For optimum results in a mobile installation, the length of the RG-58/U 50 ohm coaxial cable should be 11 ft. 9 inches, or multiples thereof (23 ft. 6 inches, etc.). Lengths other than multiples of 11 ft. 9 inches may be used when perfect antenna matching exists. However, this ideal condition is generally difficult to obtain because of a number of factors which affect impedance, such as the type of antenna, its tuning, its height above ground, and the transmission line employed.

When the use of the particular lengths specified results in an over-long line, the excess should be wound in a neat coil not less than 8 inches in diameter.

In a base station installation, an exceptionally long lead-in cable may be required. When lengths of over 50 feet are necessary, RG-8/U coaxial cable is more suitable since it offers lower loss than RG-58/U.

## MOBILE ANTENNAS

The type of antenna best suited for mobile service is a vertically polarized whip antenna. The vertical whip is non-directional and can be of the loaded type (top, center or base loaded), or a full quarter-wave, the latter usually being more efficient. Both types use the metal body of the vehicle as a "ground plane". There are a number of locations that may be used for the installation of an antenna on a car. Four of the most popular locations are those shown in Figure 3.

### FRONT COWL MOUNTING

Front cowl mounting offers a number of advantages. The CB antenna can be mounted in place of the regular auto radio antenna and will thus provide the minimum of installation problems. The antenna can then be used for both the CB and standard auto radio by employing any of the commercially made two-way couplers available (such as the Lafayette HP-202, Stock #42-0903). In this location you can install a short loaded whip, with only a small loss of efficiency.

The horizontal radiation pattern in such a location is slightly irregular, radiation being slightly greater in the direction of the rear fender opposite to the side on which the front cowl antenna is mounted.

### ROOF MOUNTING

Roof mounting is usually the best location because it provides an almost perfect omnidirectional radiation pattern. However, the use of a full 108-inch quarter-wave antenna on the roof of a vehicle is fairly impracticable and a shorter loaded whip is usually installed in this location, even though this type offers lower efficiency.

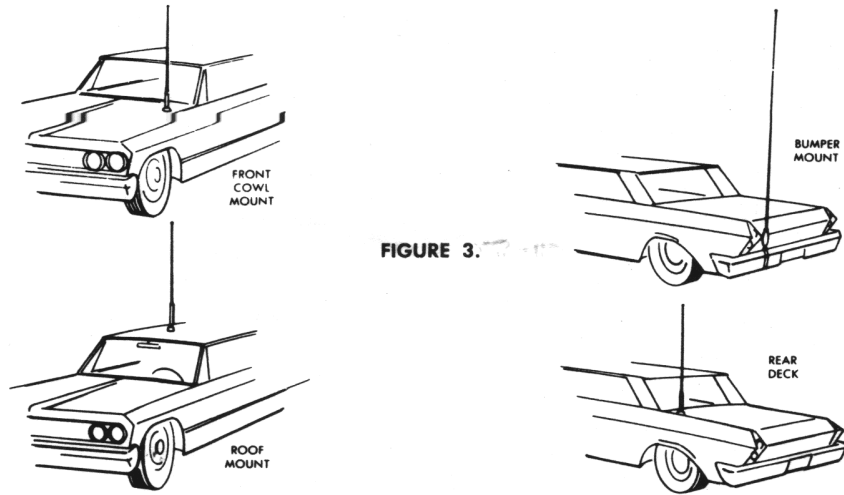

### REAR DECK MOUNTING

Rear deck mounting permits the use of a full quarter-wave antenna or a shorter, loaded whip. The radiation pattern in such a location is somewhat irregular, radiation being slightly greater in the direction of the front fender opposite to the side on which the rear deck antenna is mounted.

### BUMPER MOUNTING

This arrangement uses the rear bumper of the car and is by far the most practical for use with full 108-inch quarter-wave whips. Another advantage is that removal of the antenna is simple and leaves no holes in the car body. The radiation pattern produced by an antenna mounted on the left rear bumper is fairly irregular, with greatest radiation being in two directions -- one to the right and forward slightly, the other to the rear and left slightly.

## BASE STATION ANTENNAS

### SHORT RANGE

The Lafayette HE-19 (Lafayette Stock No. 99-3015) is a small base loaded whip designed for short range communications work -- intercommunication between buildings, etc. It mounts directly onto the back of the transceiver. Extended -- it measures 45", closed -- 15".

### LONG RANGE

There are three basic types of long-range antennas as shown in Figure 4.

A. Vertical Ground Plane Antennas. These are omnidirectional antennas that provide optimum performance for contacting other fixed stations using vertical type antennas in addition to all mobile stations. For medium and long-range communications work.



FIGURE 4.



- B. Coaxial Antennas. These are high efficiency type radiators with omnidirectional characteristics, performing as well in most applications as the ground plane type. Ideal for those installations where a vertical ground plane is not feasible. For medium and long range communications work.
- C. Directional Beam Antennas. Highly efficient and directional antennas generally intended for fixed-to-fixed long range communications. An average 3-element beam provides an equivalent of 8 db increase in transmitter power.

### IGNITION INTERFERENCE

#### AUTO

The suppression carried out on vehicles equipped with a standard broadcast radio will usually prevent any serious ignition interference from occurring. However, because of the high sensitivity of the receiver, sufficient noise may be picked up from your own vehicle to make reception of weaker stations difficult. In such a case, additional suppression is recommended. Several noise suppressor kits are available (such as the Lafayette HP-204, Stock No. 42-0905) which include all necessary parts and instructions for effectively suppressing ignition noise. Alternatively, you can take the vehicle to a skilled auto radio technician who will be able to carry out the suppression for you.

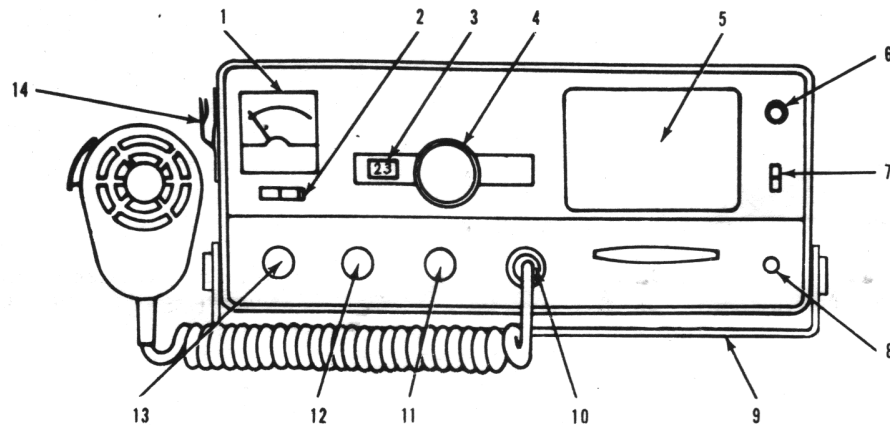

#### OPERATING CONTROLS AND FEATURES

- (1) ILLUMINATED METER ..... Automatically indicates relative strength (in "S" units) of incoming signal or RF antenna power (in watts) of the transmitter.
- (2) RANGE-BOOST ..... Concentrates more audio power into the transmitted sidebands by providing high average modulation on all syllables. Offers maximum communication distance when noisy conditions make reception of your signal difficult.
- (3) CHANNEL INDICATOR ..... Illuminated dial shows channel to which the transceiver is set.
- (4) CHANNEL SELECTOR ..... Continuously rotating switch that selects any one of 23 CB channels
- (5) SPEAKER ..... PM-type 5" round speaker located behind grille.
- (6) MODULATION INDICATOR ..... Functions as modulation indicator on transmit.
- (7) PA-CB ..... "CB" position provides normal operation. "PA" position permits Public Address operation on transmit using an external speaker. On receive, "PA" position provides channel monitoring over the external speaker.

- (8) PHONE JACK ..... Standard phone jack for headphones or external speaker (4-8 ohms). Insertion of plug into the jack automatically silences the internal speaker.
- (9) MOUNTING BRACKET ..... Specially designed mounting bracket simplifies mobile installation -- also permits fast removal of transceiver.
- (10) MICROPHONE ..... Four-pin socket for push-to-talk ceramic microphone with coiled cord and dependable screw-on connector.
- (11) FINE TUNING ..... Permits "fine" tuning of receiver for reception of stations that are off frequency.
- (12) VOLUME/ON-OFF ..... Varies the sound output from the speaker. Also incorporates an on-off power switch at the extreme counter-clockwise position.
- (13) SQUELCH/STANDBY ..... This control is used to "quiet" the receiver during "no-signal" conditions. Degree of sensitivity to incoming signals is adjustable. Fully counter-clockwise position switches to standby.
- (14) MICROPHONE CLIP ..... Hang-up clip for microphone (supplied separately for installation in various positions).

## OPERATING INSTRUCTIONS

Make sure the transceiver is properly installed for base or mobile operation (as indicated previously), and that the antenna and power source are connected. If you have not already done so, connect the microphone.

### RECEIVING

Place the PA-CB switch in the CB position, rotate the squelch control to the extreme counter-clockwise position (without operating the standby switch), and select desired channel. Rotate the volume control knob until the switch clicks. The "S" meter dial light should glow softly. Advance the volume control to about 1/3 setting. As the unit warms up, the characteristic noise (rushing sound) of a high gain receiver should be heard. Adjust to a comfortable listening level. The receiver is now ready to operate.

### SQUELCH ADJUSTMENT

The Squelch control is used to eliminate annoying background noise when no signals are present. To adjust the SQUELCH control properly during reception, turn up VOLUME until background noise is heard (no signals should be present). Rotate the SQUELCH slowly clockwise until the background noise just disappears. At this point, the receiver will be relatively quiet under "no-signal" conditions, but an incoming signal will overcome the squelch action and be heard. Since this control is variable, it can be used to provide varying degrees of sensitivity to incoming signals. As the control is advanced (from the extreme counter-clockwise position), the squelch action is progressively increased and progressively stronger incoming signals are needed to overcome it. To receive extremely weak signals or to disable the squelch circuit, simply turn the control fully counter-clockwise -- but without operating the Standby switch.

In the "Standby" position of the Squelch control, the high voltages (B+) in the transceiver are switched off but filament voltages are still maintained. This reduces power consumption when the unit is not in actual use while allowing the transceiver to remain in a "warmed-up" condition ready for instant use when needed (simply rotate Squelch clockwise to operate the switch).