

# DB-347B Channel Display Board

Fits: Galaxy DX-33HML, DX-44HL, Connex CX-3300, CX-4400, General Lee, Hill, & More!

Converts Display to Blue Channel Readout and RX/TX LED to Blue and Red!

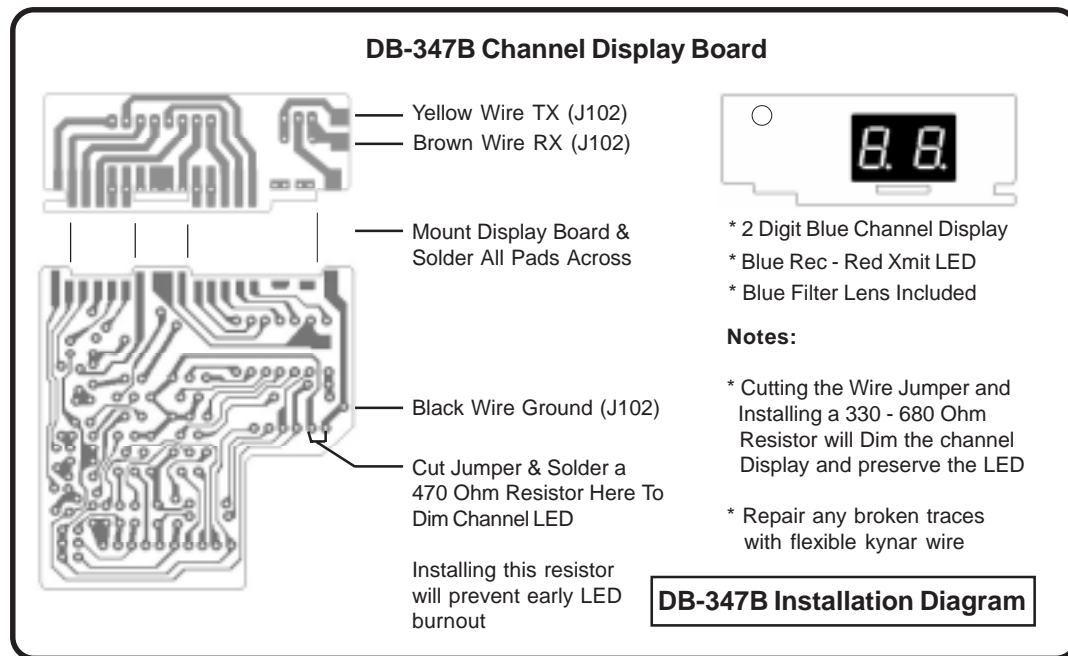

## Installation:

- \* Remove the covers and carefully pry off the knobs from the radio face making sure not to damage the bezel.
- \* Remove the screws holding the bezel in place and carefully unplug the ribbon wire connector from the channel board.
- \* Remove the radio bezel and the two screws holding the channel board in place.
- \* Unsolder the three wires from the original display board connected at jumper J102
- \* Carefully unsolder and separate the original display board from the channel board trying not to break the traces. These boards are delicate and not as strongly bonded as the traces on the fiberglass DB-347 board.
- \* Insert the new DB-347 board into the slots of the channel board and solder all traces connecting the two boards together. If any traces are broken, repair them with Kynar wire (Available at Radio Shack and other electronic stores)
- \* Solder the three wires from J102 to the DB-347 board as shown in the diagram above.
- \* Cut the jumper on the channel board and solder a 470 ohm resistor across the two sides of the jumper. This is necessary because the new LEDs on the DB-347 use less current and are considerably brighter (Prevents LED burnout)
- \* Remove the original lens material from the bezel, and mount the new material into the channel window. Trim to size with scissors if necessary.
- \* Re-assemble the radio and check all connections if problems are encountered. Problem areas are usually broken traces, loose ribbon wires, ground connections